

General

HFSH series TTQ top entry ball valve is a newly made product based on the advanced technology of foreign countries. It is designed from the separate valve body of the common ball valve into a new type integral sloping valve. The said valve has been commonly used in many foreign countries in the recent years in place of gate valve, stop valve, pillar valve and other valves. It is the most ideal valve which is now used in a wide range such as petrochemical, metallurgical, electrical, textile, medical industries and the departments of environmental protection and feedwater & drain. The valves can be applied not only to the control of liquid, gas and steam, but also to the control of the waste water and fibred, grained, sticky fluid, which other valves can not be applied to.

Features

- Unique structure of seat and body
- Excellent tightness.
- Fire-proof structure.
- Static-electricity-proof property.
- Stem-shoot-up prevention.
- Packing flat-surface tightness.

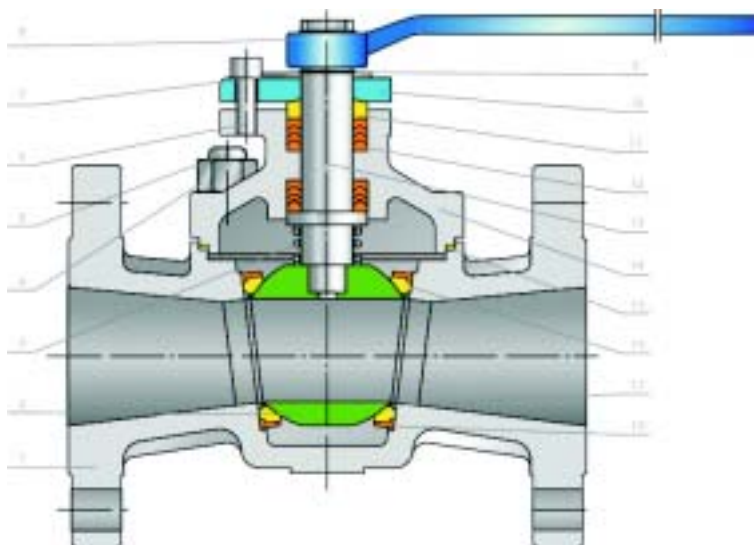

Standards

- Basic design: API 608
- Flanged ends: ASME B16.5
- Face to face: ASME B16.10
- Inspection and test: API 598

Series TTQ material specifications

No.	Parts	Standard	Stainless Steel	Sour Service	Low Temperature Service
1	Body	ASTM A216 WCB	ASTM A351 CF8M	ASTM A216 WCB	ASTM A352 LCB
2	Ball	ASTM A105/ENP	ASTM A182 F316	ASTM A105/ENP	ASTM A350 LF2/ENP
3	Spring	304S.S.	316S.S.	304S.S.	304S.S.
4	Nut	ASTM A194 2H	ASTM A194 8	ASTM A194 2HM	ASTM A194 7M
5	Stud	ASTM A193 B7	ASTM A193 B8	ASTM A193 B7M	ASTM A320 L7M
6	Bolt	ASTM A193 B7	ASTM A193 B8	ASTM A193 B7M	ASTM A320 L7M
7	Stop Plate	Carbon Steel	S.S.	Carbon Steel	S.S.
8	Lever	Carbon Steel	Carbon Steel	Carbon Steel	Carbon Steel
9	Retainer	S.S.	S.S.	S.S.	S.S.
10	Gland Flange	ASTM A216 WCB	ASTM A351 CF8M	ASTM A216 WCB	ASTM A352 LCB
11	Gland	ASTM A276 420	ASTM A182 F316	ASTM A276 420	ASTM A182 F316
12	Packing	PTFE	PTFE	PTFE	PTFE
13	Stem	ASTM A182 F6a	ASTM A182 F316	ASTM A182 F6a	ASTM A182 F316
14	Bonnet	ASTM A216 WCB	ASTM A351 CF8M	ASTM A216 WCB	ASTM A352 LCB
15	Gasket	PTFE	PTFE	PTFE	PTFE
16	Seat	PTFE	PTFE	PTFE	PTFE
17	Inner Ring	ASTM A276 420	ASTM A182 F316	ASTM A276 420	ASTM A182 F316
18	Outer Ring	ASTM A276 420	ASTM A182 F316	ASTM A276 420	ASTM A182 F316



Series TTQ Top Entry Type Floating Ball Valves

Series TTQ Top Entry Type Floating Ball Valves Structure Properties

Fire-proof structure

A fire-proof metal ring is set between ball and seat in case the accidental fire breaks out or high temperature damages the valve seat and too much leakage occurs. When the seat is burned and damaged, the ball is compacted tightly upon the ring to ensure some degree of tightness and the safety of the system

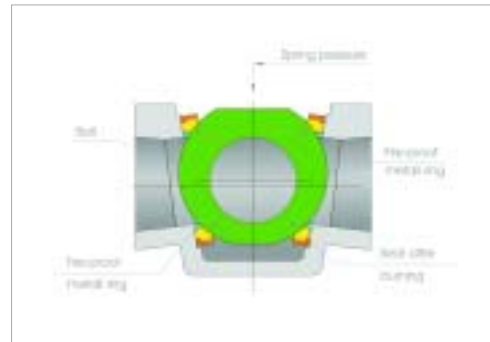

FIRE-PROOF STRUCTURE

Stem-shoot-up prevention

As for the common ball valve, if the packing around the stem bumps out or there is something wrong with the packing cover and the bolt, the stem will be driven off by the inside pressure and the medium will overflow so that a serious accident will happen. In order to prevent the danger caused by the high pressure inside the valve, a shoulder is designed at the lower part of the stem and the stem will not be driven off.

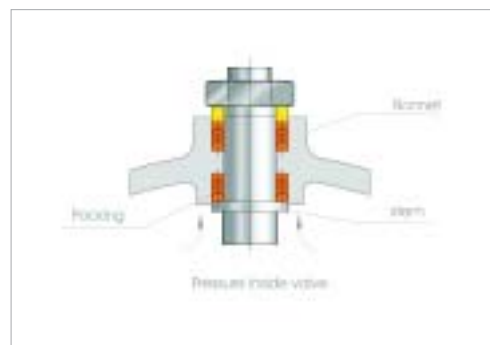

STEM-SHOOT-UP PREVENTION

Packing flat-surface tightness

We used to put packing around the stem and compact to ensure tightness of the stem which sticks out of the cover. But now we apply the pretightening force of the spring to the surface between the packings and that between the stem shoulder and the cover shoulder to ensure tightness. The opening torque will be reduced.

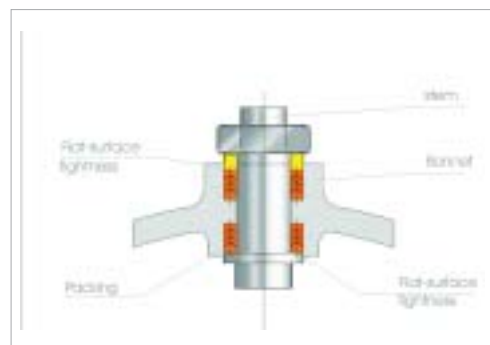

PACKING FLAT-SURFACE TIGHTNESS



Series TTQ Top Entry Type Floating Ball Valves

Series TTQ Entry Type Floating Ball Valves Desing

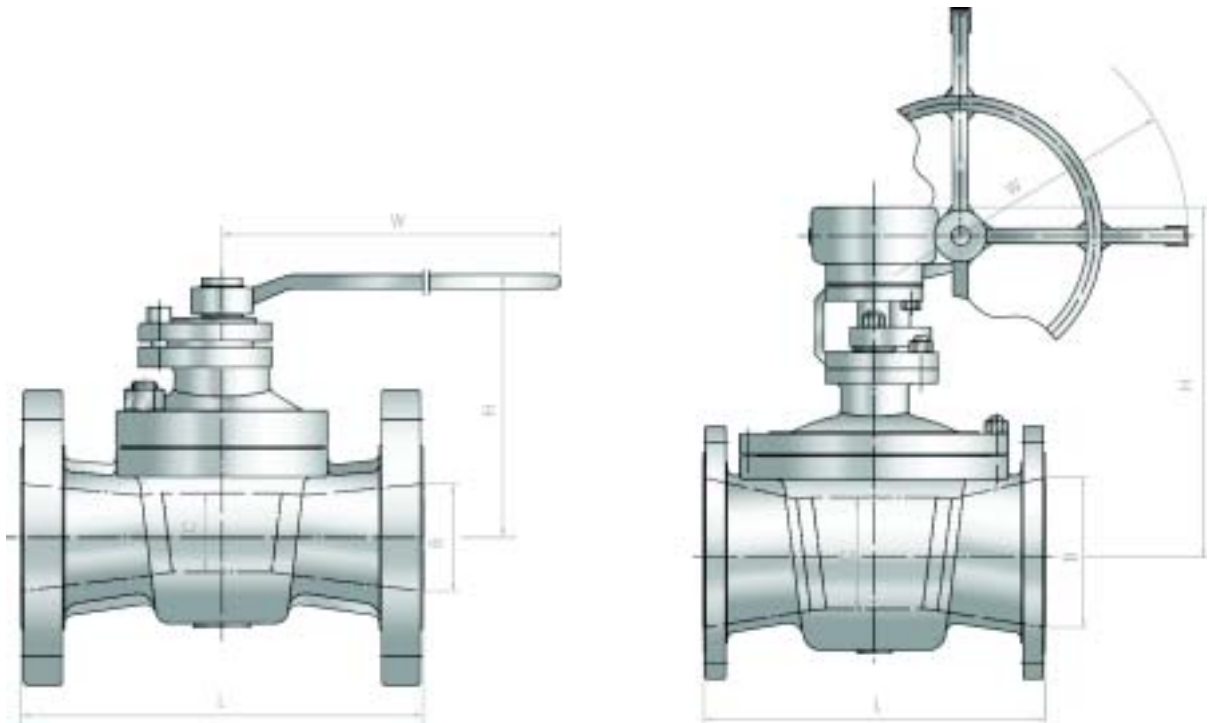

Dimensions(150lb)

Size (in.)	1/2	3/4	1	1-1/4	1-1/2	2	2-1/2	3	4	5	6	8	10
C (mm)	9.5	13	20.6	25	30.2	38	51	57.2	76.2	102	114.3	152.4	190.5
B (mm)	13	19	25	32	38	51	64	76	102	127	152	203	254
L (mm)	108	117	127	140	165	178	190	203	229	356	394	457	533
H (mm)	100	100	100	120	120	140	180	210	220	230	320	380	420
W (mm)	140	140	140	190	190	230	320	320	450	450	450*	660*	660*
Weight (Kg)	2.5	3.2	3.5	6.5	7.2	8.5	14.8	25	35	75	135	193	275

Dimensions(300lb)

Size (in.)	1/2	3/4	1	1-1/4	1-1/2	2	2-1/2	3	4	5	6	8	10
C (mm)	9.5	13	20.6	25	30.2	38	51	57.2	76.2	102	114.3	152.4	190.5
B (mm)	13	19	25	32	38	51	64	76	102	127	152	203	254
L (mm)	140	152	165	178	190	216	241	283	305	381	403	502	568
H (mm)	100	100	100	120	120	140	180	210	220	230	320	380	420
W (mm)	140	140	140	190	230	230	320	450	450	450	450*	660*	660*
Weight (Kg)	3.0	4.2	4.2	10.5	12	13.5	24	37.5	41	78	147.5	207	296

Notes: The size NO* is turbine stem structure size DN150~250 can fit a handle as well