



## Series SQ 3pcs Floating Ball Valves

**Class 800**

*Three-Piece, Split Body, Forged Steel, Side Entry Design*

### Features

- Three Pieces body construction.
- Blowout-proof stem.
- Locking devices available.
- Live-loading available.

### Standards

- Basic design:API 608
- Socket welding ends:ASME B16.11
- Inspection and test:API 598

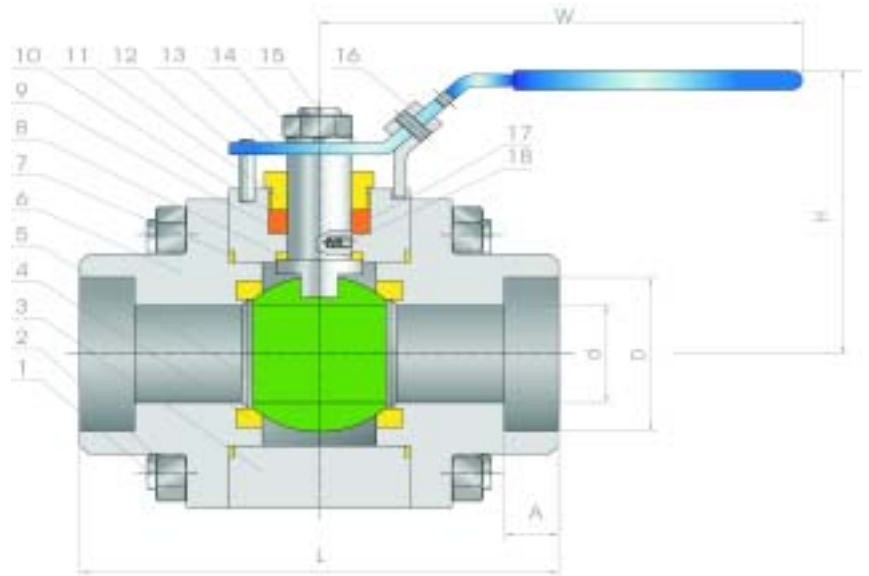

### Part List

No.	Parts	Material
1	Bolt	ASTM A193 B7
2	Nut	ASTM A194 2H
3	Body	ASTM A105
4	Seat	PTFE
5	Ball	ASTM A182 F316
6	Body Cap	ASTM A105
7	Gasket	PTFE
8	Thrust Washer	PTFE
9	Stem	ASTM A182 F6a
10	Packing	PTFE
11	Gland	ASTM A276 410
12	Stop Pin	ASTM A276 410
13	Lever	Ductle Iron
14	Washer	AISI A1065
15	Nut	S.S.
16	Lock	S.S.
17	Autistatic Spring	S.S.
18	Grounding Plugger	S.S.

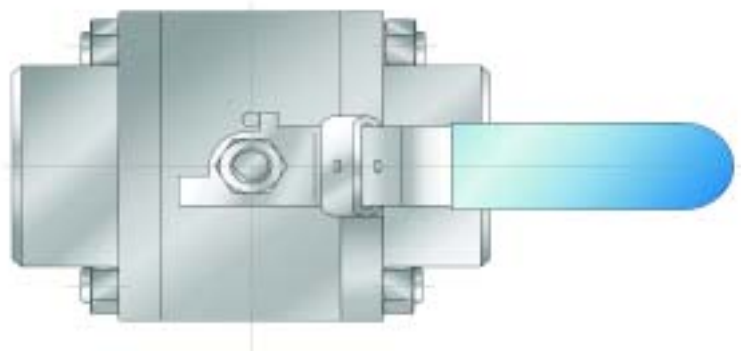

### Dimensions (800lb)

NPS	L	d	D	A	W	H	W.T (KG)
1/2"	80	12.7	22	9.5	150	73	1.2
3/4"	95	19	27.4	12.5	170	78	2.1
1"	110	25.4	34	12.5	170	95	3.4
1-1/2"	140	38	48.8	12.5	250	115	5.8
2"	165	51	61.2	16	300	140	8.2